

## Filterless Central Hopper Receivers

*Designed to provide rapid transportation of free-flowing virgin pellets and regrind direct to your processing machine*

Comet's CHR-U filterless central hopper receivers are an integral part of any material loading system. There are two types of CHR-U loaders available to control the material level:

1. **Vacuum Hopper (U):** Vacuum-style, with a magnetic reed switch, mounts directly on a dryer or machine hopper.
2. **Photosensor Hopper (U-E):** Photosensor control-style, that can be installed directly on a molding machine feed throat.

Both have an internal diaphragm valve to work with a central vacuum pump and central control to perform reliable, consistent production.

### Standard Features

- 100% corrosion-free stainless steel hoppers prevent pellet contamination and increase the loader's lifespan.
- Reed switch on the vacuum hopper guarantees material is supplied on time and without interruption.
- Photosensor switch accurately controls the loading process.
- Vacuum diaphragm valve inside the loader ensures continuous material loading, prevents material shortages and enables the loader to be auto-controlled by a centralized system.
- Internal stainless steel mesh filter prevents material from being sucked into the vacuum line.
- All the hoppers (except the CHR-48U and higher) have a quick-disconnect vacuum head ensuring fast cleanup time and easy maintenance.
- 6-pin plug ensures safety and a reliable performance.
- ON/OFF switch at loader.
- If several central loaders share the same material pipe, an optional non-return valve or pneumatic non-return valve is available.



CHR-6U



CHR-6U-E

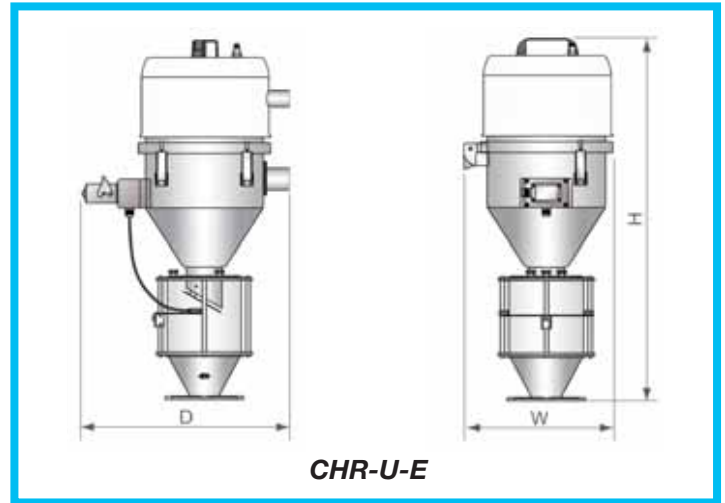
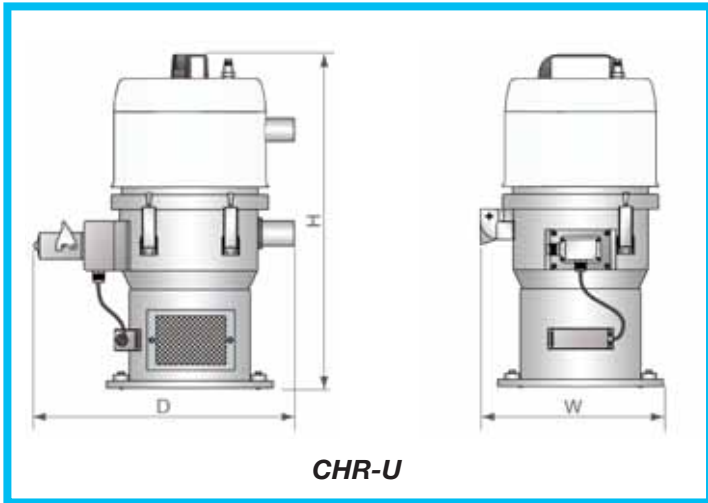

## Specifications

Model	Hopper Capacity (L)	Loading Pipe Diameter (in)	Air Suction Pipe Diameter (in)	Material Level Control Type	Dimensions H x W x D (in / mm)	Weight (lbs / kg)
CHR-6U	6	1.5	1.5	Magnetic Reed Switch	16.5 x 11 x 14 420 x 285 x 360	13 6
CHR-6U-E				Interactive Photosensor Switches	24 x 11 x 14 600 x 275 x 360	17.5 8
CHR-12U	12	1.5	1.5	Magnetic Reed Switch	18.5 x 12.5 x 15.75 470 x 315 x 400	15.5 7
CHR-12U-E				Interactive Photosensor Switches	27.5 x 12 x 15.75 700 x 315 x 400	26.5 12
CHR-24U	24	2	2	Magnetic Reed Switch	27 x 12 x 15.75 690 x 315 x 400	20 9
CHR-24U-E				Interactive Photosensor Switches	44 x 12.5 x 15.75 1120 x 360 x 400	28.5 13
CHR-36U	36	2	2.5	Magnetic Reed Switch	36.5 x 12 x 15.75 930 x 315 x 400	24 11
CHR-48U	48	2	2.5	Magnetic Reed Switch	36.5 x 12 x 15.75 930 x 315 x 400	24 11

**Note:** 1) "E" = Installation of photosensor  
 2) Voltage: 24V DC  
 3) Air Supply: 9 - 13 lbs/in<sup>2</sup>  
 4 - 6 kg/cm<sup>2</sup>

*Specifications and dimensions are subject to change without notice.*

