

100% Corrosion-Free Stainless Steel

Easy Access/Quick Cleanup

Comet's EV-Series corrosion free, stainless steel hopper loader is designed to provide rapid transportation of free-flowing, virgin pellets and regrind directly to the process machine. The hinged vacuum head ensures quick cleanup time and easy maintenance.

The EV-Series comes complete with a Pyrex glass tube for visual confirmation of resin, and optical sensors are less sensitive to dust, delivering reliable, consistent production. The integral single-phase suction motor creates a flow of air that carries the plastic pellets into the hopper through the material line for a pre-selected time. They are then discharged directly into the processing machine feed throat. This cycle is repeated until both the machine hopper and hopper loader are full.

Reliable Performance

All units have a microprocessor control with a digital mode selection for setting and displaying loading time, loading functions, line clearing, and empty time. Fault diagnosis is provided as a standard feature of the control. All models are built to the highest standards from quality stainless steel providing consistent, reliable performance.



Standard Features

- Stainless steel construction increases loader life
- Fabric vacuum filter with stainless mesh backing for easy cleaning
- Low noise vacuum head with sound insulation
- Mechanical flap to seal the loader vacuum
- Audio alarm
- Electrical control and loader head prepared for future centralized system expansion
- Electrical circuit built to comply with CE and NFPA 79 safety requirements
- 115V single phase
- Self-cleaning filter
- Optical sensors to visually detect low material level

Options

- Material line cleaning valve and suction box
- Two-component proportioning valve
- 220V single phase

Capacities

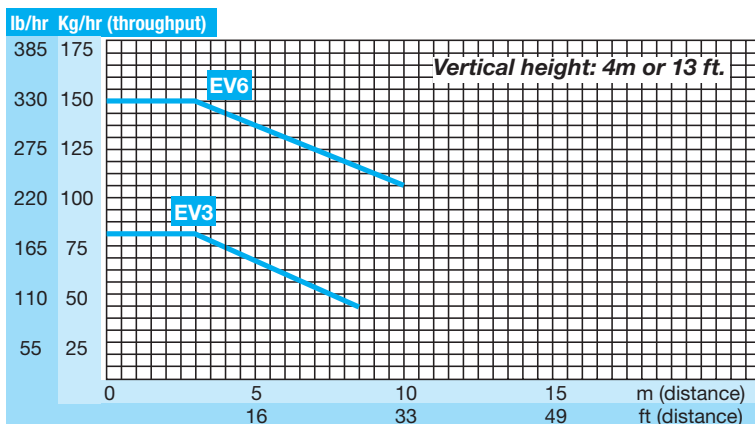

100% Corrosion-Free Stainless Steel

Easy Access/Quick Cleanup

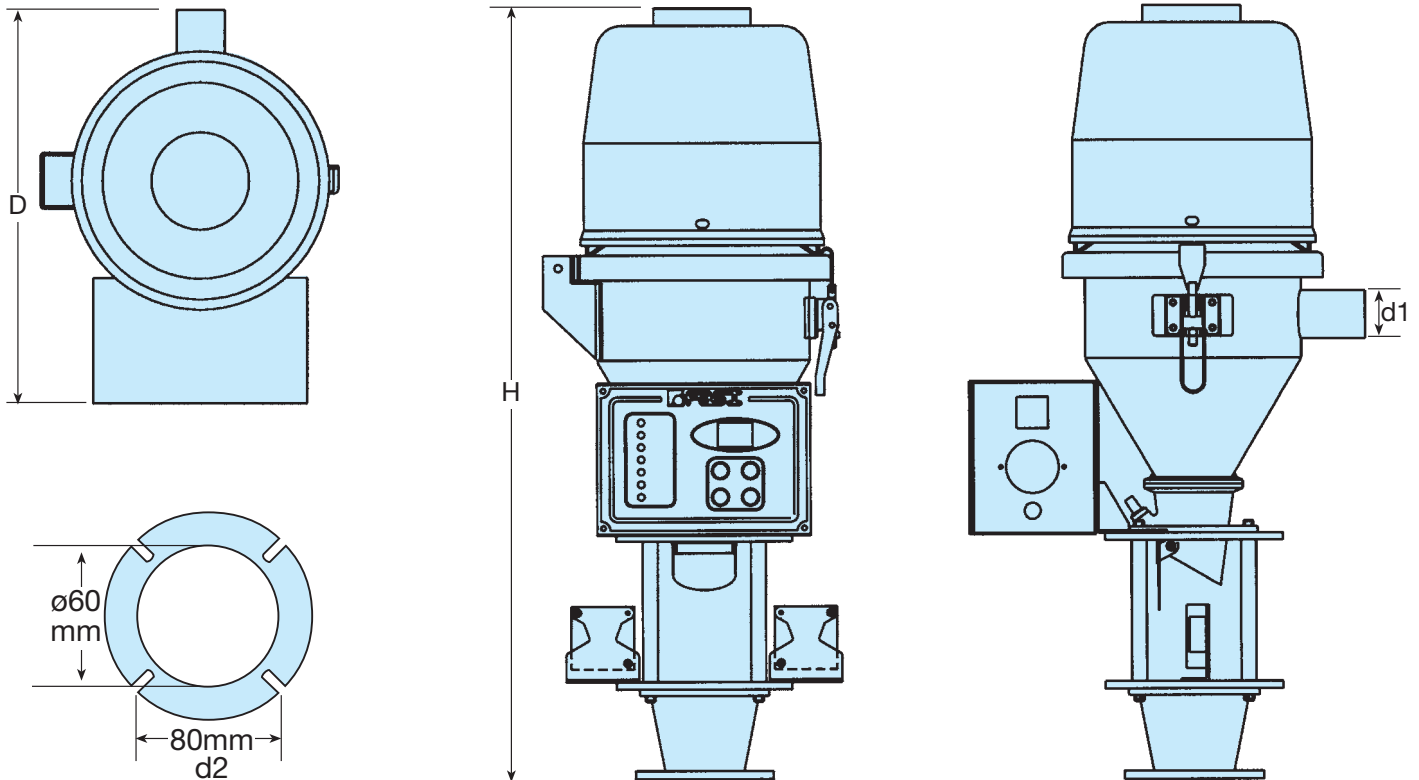

Specifications

E-Series Loaders		EV3	EV6
Hopper Capacity	liter	3	6
Motor HP	HP	1.4	1.4
Throughput (max.)	lbs/hr kg/hr	154 70	308 140
d1 – Loader Inlet Diameter	in mm	1.5 38	1.5 38
d2 – Bolt Hole Pattern (4 slots)	in mm	2.4 60 x 60	2.4 60 x 60
Depth (D)	in mm	12.3 312	13.7 347
Overall Height (H)	in mm	24.2 615	28.9 735
Weight (approx.)	lbs kg	28 13	30 13

Specifications and dimensions are subject to change without notice.

Scan this QR code with your mobile device to see our complete line of auxiliary products.



COMET

PLASTIC EQUIPMENT, LLC

6555 Garden Rd. Unit 16
Riviera Beach FL 33404

800-328-5088

Fax: (937) 296-9069

cometpe.com