

Maintenance-Free Conveying Station

Easy Access/Quick Cleanup

Comet's S-Series corrosion free, stainless steel vacuum receiver is designed for high volume conveying up to 1650 lbs./hr. The filterless receiver ensures quick cleanup time and easy maintenance while delivering central loading. The M-Series vacuum units are fully portable and feature a powerful three-phase vacuum blower, cartridge filter, and exhaust manifold.

Reliable Performance

All units have a microprocessor control with a digital mode selection for setting and displaying loading time, loading functions, line clearing, and empty time. The M-Series vacuum unit is capable of connecting to as many as six S-Series receivers. Fault diagnosis is provided as a standard feature of the control. All models are built to the highest standards from quality stainless steel providing consistent, reliable performance. The S-Series is the first affordable alternative to costly central vacuum systems.

Standard Features

- Stainless steel construction.
- Double filtration protection to prolong pump life.
- Motor overload protection with alarm.
- Mechanical flap (or optical sensor.)
- Easy clean cartridge filter.
- Audible alarm.
- Electrical control prepared for future centralized system expansion.
- Electrical circuit built to comply with NFPA 79 safety requirements.

Options

- Material line cleaning valve and suction box
- Two-component proportioning valve
- 220V single phase



Capacities

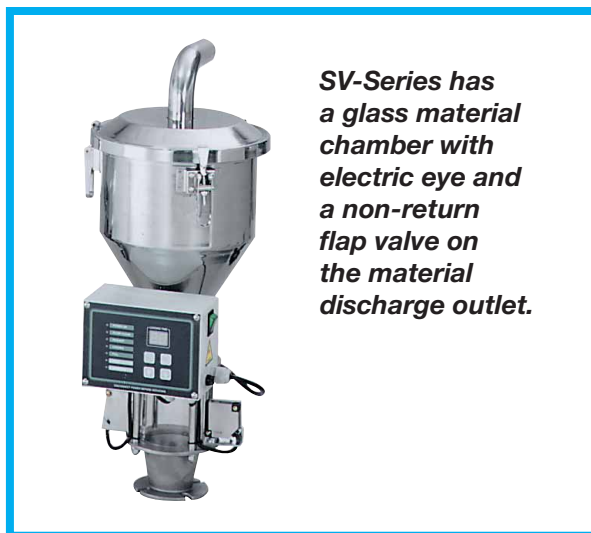
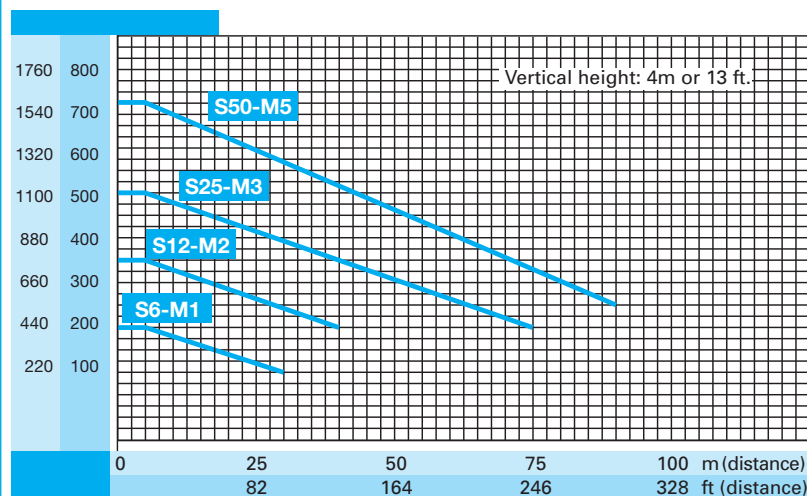

SV-Series has a glass material chamber with electric eye and a non-return flap valve on the material discharge outlet.

Maintenance-Free Conveying Station

M-Series Vacuum Units

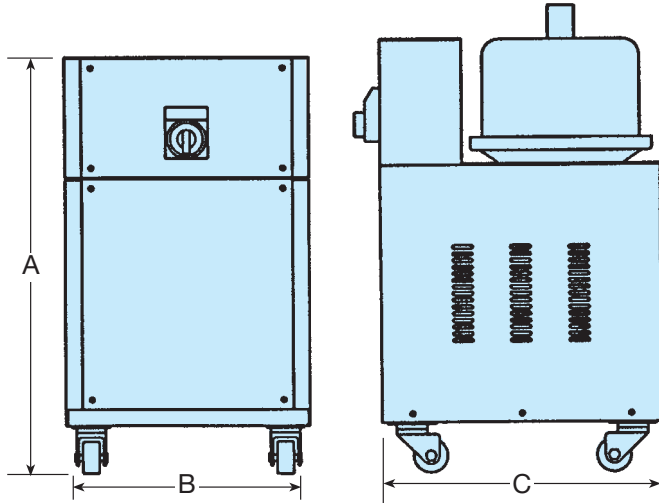

S-Series

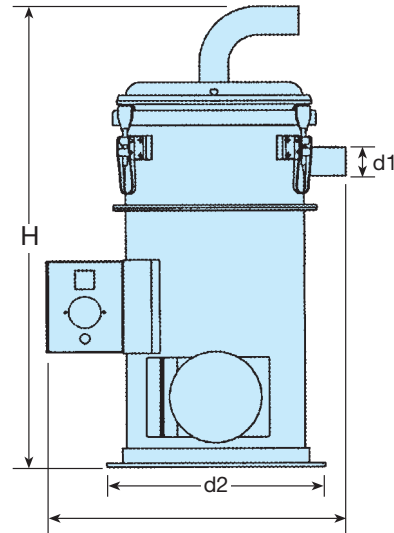

SV-Series

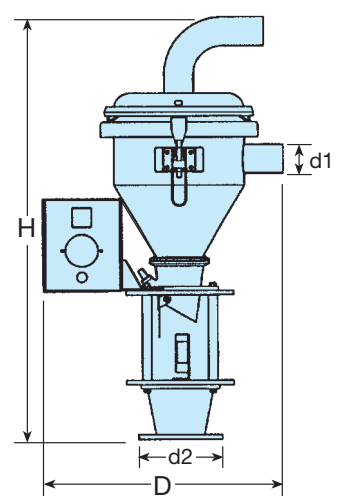

Specifications

S-Series Receivers		SV3	SV6	S3	S6	S12	S25	S50
Hopper Capacity	liter	3	6	3	6	12	25	50
d1 – Loader Inlet Diameter	in	1.5	1.5/2	1.5	1.5/2	1.5/2	1.5/2	2/2.5
d2 – Bolt Hole Pattern (4 holes)	in	2.4 x 2.4	2.4 x 2.4	8.4	10.4	10.4	15.4	20.5
	mm	60 x 60	60 x 60	214	265	265	390	520
Depth (D)	in	12.3	13.7	13.1	13.7	13.7	18.9	22.8
	mm	312	347	334	347	347	480	580
Overall Height (H)	in	21.3	25.9	16.9	21.7	27	30.7	33.5
	mm	540	658	430	550	685	780	850
Weight (approx.)	lbs	20	25	20	22	26	33	40
	kg	10	11	9	10	12	15	18
M-Series Vacuum Units		M2	M3	M5	M6	M8		
Blower	HP	2	3.5	5	6	8.5		
Throughput*	lb/hr	880	1200	1650	2500	3500		
	kg/hr	400	550	750	1140	1600		
Dimension A	in	25.6	27.5	27.4	27.4	27.4		
	mm	650	695	695	695	695		
Dimension B	in	17.6	19.1	19.1	19.1	19.1		
	mm	447	485	485	485	485		
Dimension C	in	14.7	16.5	16.5	16.5	16.5		
	mm	374	420	420	420	420		
Weight (approx.)	lbs	60	90	110	140	160		
	kg	28	40	50	64	73		

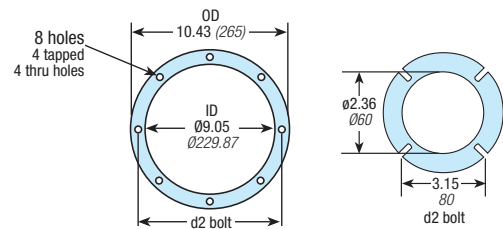

Scan this QR code with your mobile device to see our complete line of auxiliary products.

