

## 100% Corrosion-Free Stainless Steel Hot Air Dryers

*Unique hot air down-blowing design ensures hot air is evenly distributed.*

Comet's CHD-U Series corrosion free stainless steel hot air hopper dryers are ideally suited as a stand-alone unit or to use with honeycomb matrix dehumidifiers to dry engineered plastics.

There are 25 models available ranging from 56 to 11,200 lbs. Airtight material clean-out doors are available on models CHD-80U and above. The microprocessor control features a digital display and an auto start/stop timer as standard equipment.

### Standard Features

- Microprocessor for accurate temperature control.
- Overheat protection ensures reliable operation.
- Hot air, down-blowing design ensures hot air is evenly distributed to maintain a steady temperature in the hopper and increase drying efficiency.
- Digital PID temperature controller with LED display.
- Over-heat protection ensures reliable operation.
- 7-day start/stop timer improves energy consumption and saves you money.
- Models CHD-80U and above have a material cleanout door ensuring quick cleanup time and easy maintenance.
- Models CHD-450U and below have a stainless steel lined aluminium base.
- Models CHD-600U~1200U have an aluminium magnetic base.
- Models CHD-1500U and model above have a manual butterfly valve.
- Models CHD-900U and above come with a floor.

### Options

- Access ladder for models CHD-1500U and above.
- Fully insulated drying hopper and lid for high temperature applications.
- Hot air recycler, suction box, magnetic hopper floor stand and storage hopper.



CHD-300U



CHD-1500U with optional Access Ladder

# CHD-U Series

## Optional Accessories



### Material Suction Boxes

Designed to work with dryers having a floor stand and vacuum loader (built-in discharge gate).

SBU	Model	CHD-20U~120U	CHD-160U
SBU		-20-38S	-160-38S
SBU		-20-50S	-160-50S
SBU		-20-38D	-160-38D
SBU		-20-50D	-160-50D

Note

1) Single tube suction box (plus "S" at the back of unit)

2) Double tube suction box (plus "D" at the back of unit)



### Hopper Magnets

Captures metal scraps in the material to prevent damage to the plasticizing screw.

Model	Applicable Model	Aluminum Holder
MR-5	CHD-20U	(148 x 80 x 2.3) x 2
MR-7	CHD-40U~80U	(190 x 80 x 2.3) x 2
MR-9	CHD-160U~600U	(240 x 80 x 2.3) x 2
MR-11	CHD-900U and above	(298 x 80 x 2.3) x 2

## Floor Stands

Easy installation and transportation of dryer and hopper loader.



**Floor Stand**  
(CHD-20U~750U)



**Floor Stand**  
(CHD-900U~8000U)

## Magnetic Bases

Works with dryer to capture metal scrap to prevent contamination.



Model	Applicable Model	Magnet Type	Aluminum Holder
MB-12	CHD-20U	MR-3	(88.5 x 78 x 2.3) x 2
MB-20			
MB-50	CHD-40U ~ 120U		(88.5 x 78 x 2.3) x 2
MB-40U			
MB-100	CHD-160U~450U		(118.5 x 105 x 2.3) x 2
MB-160U			

Note: "U" represents stainless steel base.

Model	Applicable Model	Dimensions (mm)		
		Length	Width	Height
FSU-20	CHD-20U	550	450	790
FSU-40	CHD-40U			
FSU-80	CHD-80U / 120U	722	552	840
FSU-160	CHD160U / 230U	795	652	920
FSU-300	CHD-300U / 450U	930	790	970
FSU-600	CHD-600U / 750U	1200	1000	1130
FSU-900	CHD-900U / 1200U	1200	1200	1320
FSU-1500	CHD-1500U / 2000U	1500	1500	1400
FSU-2500	CHD-2500U~3500U	1640	1640	1500
FSU-4000	CHD-4000U~5500U	1900	1900	1650
FSU-6000	CHD-6000U~8000U	2100	2100	1850

### Blower Inlet Filters

Effectively filters 80% of the dust in the air to the dryer to avoid pollution.



Model	Filtering Barrel Dia. (mm)	Air Inlet Pipe Dia. (mm)	Air Outlet Pipe Dia. (mm)	Applicable Models	Fixed Plate	Air Inlet Blower Flange (with air quantity adjustor)
AIF-20U	160	1.5"	2"	CHD-20U	CHD-20U	0.12 kW Blower
AIF-40U	160	1.5"	2"	CHD-40U	CHD-40U	0.12 kW Blower
AIF-80U	225	2"	3"	CHD-80U / 120U	CHD-80U / 120U	0.12 kW Blower
AIF-160U	225	2.5"	3"	CHD-160U / 230U	CHD-160U / 230U	0.18 kW Blower
AIF-300U	225	2.5"	4"	CHD-300U / 450U	CHD-300U / 450U	0.25 kW Blower
AIF-600U	225	3"	4"	CHD-600U / 750U	CHD-600U / 750U	0.55 kW Blower
AIF-900U	225	4"	4"	CHD-900U / 1200U	CHD-900U / 1200U	0.55 kW Blower
AIF-1500U	260	5"	5"	CHD-1500U / 2000U	CHD-1500U / 2000U	3 kW Blower
AIF-2500U	340	6"	6"	CHD-2500U / 3500U	CHD-2500U / 3500U	5.5 kW Blower
AIF-4000U	340	8"	8"	CHD-4000U / 5000U	CHD-4000U / 5000U	7.5 kW Blower
AIF-5500U	420	8"	8"	CHD-5500U / 7000U	CHD-5500U / 7000U	12 kW Blower
AIF-8000U	420	8"	8"	CHD-8000U	CHD-8000U	22 kW Blower

### Hot Air Recyclers

Works with hopper dryer enabling hot air to form a semi-sealed circulated loop.

**Features:**

- 1) Hot air recycling and circulating to prevent indoor temperature from rising.
- 2) Keeps factory air clean and ensures product quality.
- 3) Economical, saves up to 40% energy consumption.
- 4) Compact design makes it suitable for all hoppers.
- 5) Adjustable air supply.



Model	Filtering Barrel Dia. (mm)	Air Inlet Pipe Dia. (mm)	Air Outlet Pipe Dia. (mm)	Applicable Models	Fixed Plate	Air Inlet Blower Flange (with air quantity adjustor)
HAR-20U	160	1.5"	2"	CHD-20U	CHD-20U	0.12 kW Blower
HAR-40U	160	1.5"	2"	CHD-40U	CHD-40U	0.12 kW Blower
HAR-80U	225	2"	3"	CHD-80U ~ 120U	CHD-80U ~ 120U	0.12 kW Blower
HAR-160U	225	2.5"	4"	CHD-160U ~ 230U	CHD-160U ~ 230U	0.18 kW Blower
HAR-300U	225	2.5"	4"	CHD-300U ~ 450U	CHD-300U ~ 450U	0.25 kW Blower
HAR-600U	225	3"	4"	CHD-600U ~ 750U	CHD-600U ~ 750U	0.55 kW Blower
HAR-900U	225	4"	4"	CHD-900U	CHD-900U ~ 1200U	0.55 kW Blower
HAR-1200U	225	4"	4"	CHD-1200U	CHD-1200U	1.1 kW Blower
HAR-1500U	280	5"	5"	CHD-1500U ~ 2000U	CHD-1500U ~ 2000U	3 kW Blower
HAR-2500U	340	6"	6"	CHD-2500U ~ 3500U	CHD-2500U ~ 3500U	5.5 kW Blower
HAR-4000U	340	8"	8"	CHD-4000U ~ 5000U	CHD-4000U ~ 5000U	7.5 kW Blower
HAR-5500U	420	8"	8"	CHD-5500U ~ 7000U	CHD-5500U ~ 7000U	12 kW Blower
HAR-8000U	420	10"	10"	CHD-8000U	CHD-8000U	22 kW Blower

### Exhaust Air Filters

Effectively filters 90% of air dust contained in the air from the dryer to avoid pollution.



Model	Filtering Barrel Dia. (mm)	Air Inlet Pipe Dia. (mm)	Air Outlet Pipe Dia. (mm)	Applicable Models	Fixed Plate
ADC-20U	159	1.5"	2"	CHD-20U	CHD-20U
ADC-40U	159	1.5"	2"	CHD-40U	CHD-40U
ADC-80U	225	2"	3"	CHD-80U / 120U	CHD-80U / 120U
ADC-160U	225	2.5"	3"	CHD-160U / 230U	CHD-160U / 230U
ADC-300U	225	2.5"	4"	CHD-300U / 450U	CHD-300U / 450U
ADC-600U	225	3"	4"	CHD-600U / 750U	CHD-600U / 750U
ADC-900U	225	4"	4"	CHD-900U / 1200U	CHD-900U / 1200U
ADC-1500U	260	5"	5"	CHD-1500U / 2000U	CHD-1500U / 2000U
ADC-2500U	340	6"	6"	CHD-2500U / 3500U	CHD-2500U / 3500U
ADC-4000U	340	8"	8"	CHD-4000U / 5000U	CHD-4000U / 5000U
ADC-5500U	420	8"	8"	CHD-5500U / 7000U	CHD-5500U / 7000U
ADC-8000U	420	8"	8"	CHD-8000U	CHD-8000U

## Outline Drawings

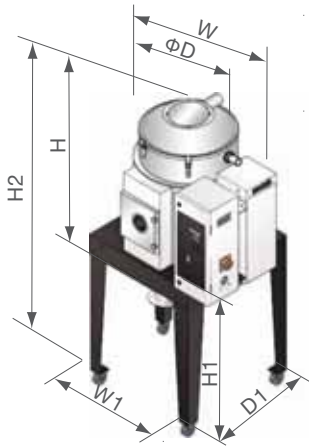

CHD-20U ~ 750U

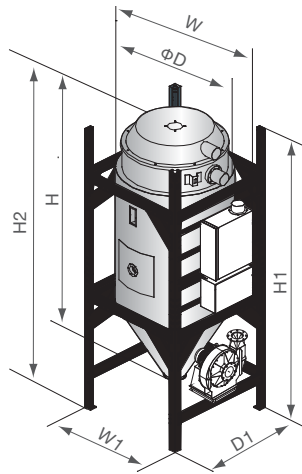

CHD-900U ~ 1200U

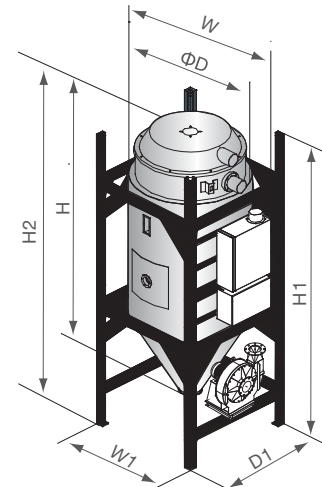

CHD-1500U ~ 8000U

## Specifications

Model	Heater Power (kW)	Blower (kW, 50/60Hz)	Loading Capacity (L)	Dimensions H x W x D (mm)	Floor Stand H1 x W1 x D1 (mm)	Height H2 (mm)	Air Inlet Pipe Dia. (in)	Air Outlet Pipe Dia. $\phi$ B (in)	Weight (kg)
CHD-20U	2.2	0.05 / 0.058	20	730 x 575 x 325	790 x 450 x 550	1260	2"	1.5"	40
CHD-40U	3	0.12 / 0.14	40	760 x 790 x 394	790 x 580 x 450	1300			70
CHD-80U	3.9	0.12 / 0.14	80	940 x 885 x 472	840 x 730 x 560	1480	2.5"	2"	85
CHD-120U	3.9	0.12 / 0.14	120	1210 x 885 x 472	840 x 730 x 560	1740			100
CHD-160U	6	0.18 / 0.20	160	1225 x 822 x 575	920 x 652 x 795	1825	3"	2.5"	90
CHD-230U	6	0.18 / 0.20	230	1505 x 822 x 575	920 x 652 x 795	2105			100
CHD-300U	12	0.25 / 0.30	300	1450 x 945 x 695	970 x 790 x 930	2085			130
CHD-450U	12	0.25 / 0.30	450	1850 x 945 x 695	970 x 790 x 930	2435			160
CHD-600U	18	0.55 / 0.63	600	1820 x 945 x 915	1130 x 1000 x 1200	2470	4"	3"	200
CHD-750U	18	0.55 / 0.63	750	2100 x 1170 x 915	1130 x 1000 x 1200	2780			220
CHD-900U	18	0.55 / 0.63	900	2173 x 1410 x 1050	2760 x 1130 x 1130	2765	4"	4"	410
CHD-1200U	24	1.1 / 1.1	1200	2598 x 1410 x 1050	3190 x 1145 x 1145	3190			560
CHD-1500U	32	3 / 3	1500	3170 x 1640 x 1250	3470 x 1340 x 1340	3470	5"	5"	685
CHD-2000U	32	3 / 3	2000	3590 x 1542 x 1250	3470 x 1340 x 1340	3870			770
CHD-2500U	58	5.5 / 5.5	2500	3735 x 1798 x 1400	3870 x 1340 x 1340	4000	6"	6"	800
CHD-3000U	58	5.5 / 5.5	3000	4135 x 1798 x 1400	4000 x 1482 x 1482	4400			900
CHD-3500U	64	7.5 / 7.5	3500	4135 x 1798 x 1400	4400 x 1482 x 1482	4800			1010
CHD-4000U	64	7.5 / 7.5	4000	4370 x 2010 x 1600	4800 x 1482 x 1482	4635			8"
CHD-5000U	80	11 / 11	5000	4860 x 2010 x 1600	5150 x 1680 x 1680	5235	1390		
CHD-6000U	96	15 / 15	6000	4600 x 2250 x 1800	4870 x 1930 x 1930	4923	1530		
CHD-7000U	112	18.8 / 18.5	7000	5830 x 2250 x 1800	5370 x 1930 x 1930	6330	1735		
CHD-8000U	128	22	8000	6030 x 2250 x 1800	5620 x 1930 x 1930	6425	10"	10"	1820

Note:

1) Blower included in net weight (floor stand not included)

2) Power supply: 3 $\phi$ , 230 / 460 / 575V, 50 / 60Hz

We reserve the right to change specifications without prior notice.

