

Soundproof Central Granulators

Regrind and recycle plastic products, such as preforms and PET bottles, while minimizing power consumption and noise.

Comet's solid, dependable CG-23/30/36 series sound-proof central granulators are designed for recycling waste or rejected parts from injection molding, blow molding or extrusion machines. This series features easy operation, quick blade replacement, and fast cleaning and maintenance. There are multiple machine sizes with cutting chamber openings up to 20" (750mm) wide, various rotor speeds, and different rotor blade configurations to allow you to select the best granulator to suit your specific requirements.

Standard Features

- Fully enclosed, completely sealed, sound-proof design assures low noise levels during granulation.
- Easy accessibility and maintenance to the cutting chamber ensures minimal downtime.
- Clamshell-like hopper opening and drop down screen chamber for quick blade replacement.
- Safety material curtain ensures no material sprinkling during granulation.
- Material inlet chute with adjustable angle for easy material feeding from a conveyor belt.
- CG-30/36 equipped with a preset knife jig.
- High quality solid steel blades for durability.
- Cyclone dust separator removes regrind dust and assists material collection even with the toughest materials.
- Dust collecting bag provides easy dust cleaning and reduces contamination.
- Compact footprint and multiple safety features.
- Equipped with electrical current relay, motor overload protection, and regrind conveying system.



CG-3650



CG-2348



CG-23 Staggered Blade Design



The **CG-23** series uses a staggered blade design to decentralize the granulation work load, increase cutting efficiency, and reduce friction and energy consumption. The blade retainer is designed for quick blade replacement without adjustment.

CG-30/36 Paddle Blade Design



The **CG-30/36** series uses a paddle blade design to easily grab and cut through materials. The blade is made of high-quality steel to ensure durability. The increased blade inclination enables a better cutting effect, lower noise, and reduced energy consumption.

Optional Accessories

Full Receiver Alarm Device



Stops the granulator and warns the user by sounding an alarm. Use for unmanned operation so materials won't be wasted. Whenever regrind levels reach the motor position, a sensor device forces the machine to stop.

Special Screens



Special screen mesh sizes:

CG-23/30 series:

Φ4, Φ6, Φ10, Φ12 (mm)

CG-36 series:

Φ8, Φ12, Φ17, Φ25 (mm)

Feed Hopper for Conveyor



It's difficult to feed material to large granulators. Usually when feeding material, installation must be at a lower level or a platform must be built. Comet's belt conveyor, for the CG-36 series, easily conveys material into the cutting chamber.

Material Side-Feed Pipe



The feed hopper design for conventional granulators is not suitable for long pipes and section bars. We have designed a material side-feed pipe for convenient feeding of long materials. A great option for the CG-36.

Feed Hopper with Magnet

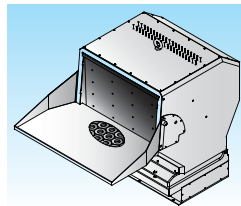

The feed hopper with magnet is used to remove metal scrap and contaminants from the material.

Cyclone Dust Separator

The cyclone dust separator is designed separate the dust from the regrind for recycling and to keep the working environment clean. The filtered dust size can be adjusted via an adjusting valve. This device ensures full use of the regrind to avoid material waste and enhance your bottom line.



DS-23/30

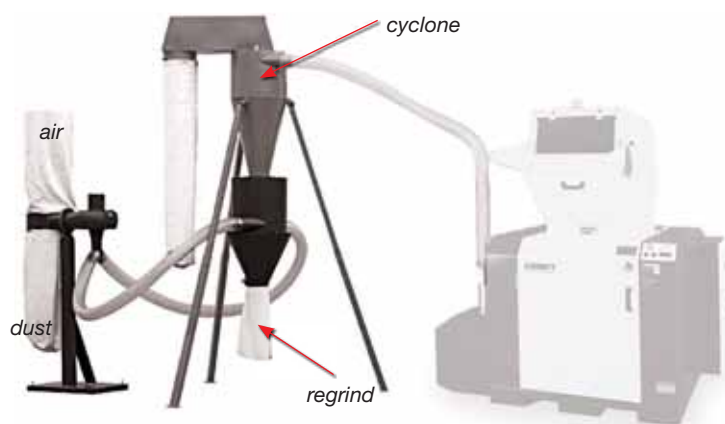

DS-36

CG-36 Specifications

Model	CG-3650	CG-3675
Motor Power (kW, 50/60 Hz)	18.5	30 / 34
Conveying Blower (kW, 50/60 Hz)	1.1 / 1.3	1.5 / 1.9
Rotor Speed (RPM 50/60 Hz)	540 / 650	540 / 650
Blade Material	SKD11	SKD11
Number of Fixed Blades	2	4
Number of Rotating Blades	6	6
Cutting Chamber (mm)	360 x 500	360 x 750
Max. Throughput (kg/hr)	620	800
Cooling Device	✓	✓
Noise Level dB(A)	100 ~ 105	100 ~ 105
Regrind Conveying System	✓	✓
Dia. of Screen Hole (φ10 mm)	✓	✓
Dia. of Screen Hole (φ8, φ12, φ17, φ25 mm)	○	○
Flywheel	✓	✓
Presetting Knife Jig	✓	✓
Full Receiver Alarm Device	○	○
Optional Conveying Blower Power (kW)	○ (1.5)	○ (2.2)
Dust Separator (DS-36)	○	○
Magnetically Charged Hood	○	○
Feed Hopper with Port	○	○
Dimensions		
H (mm)	3155	3155
H1 (mm)	1980	1980
H2 (mm)	1520	1520
H3 (mm)	2100	2100
W (mm)	1260	1510
W1 (mm)	2120	2120
W2 (mm)	480	480
W3 (mm)	190	190
D (mm)	1715	1715
D1 (mm)	1250	1250
D2 (mm)	4200	4200
Weight (kg)	1480	1730

We reserve the right to change specifications without prior notice.

- Note:**
1. ✓ = standard, ○ = optional
 2. Stainless steel feed hopper cover plate and storage tank available.
 3. When granulating plastics reinforced with fibers (e.g. CPVC), select granulators with a special quenching process in the cutting chamber and blades.
 4. SKD11 (1.2379/D2 steel): high carbon, high chromium alloy steel with high wear and corrosion resistance.
 5. Max. capacity of machine is subject to diameter of screen size and composition of material.
 6. Noise levels vary with different materials and motor types.
 7. To avoid plastic from sticking to blades, materials should be crushed at normal temperature.
 8. Power supply: 3φ, 230/400/460/575V, 50/60Hz.

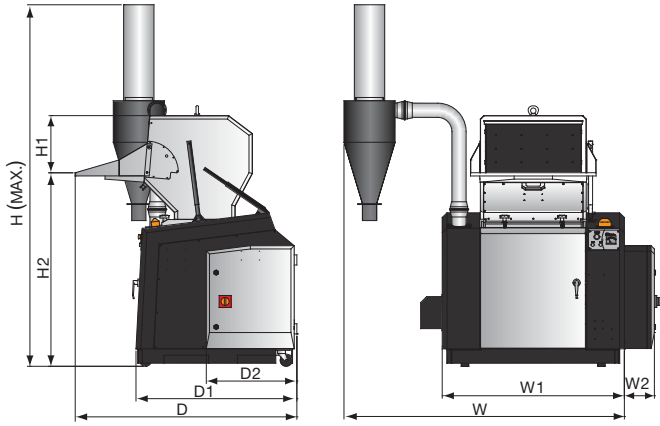

CG-23/30

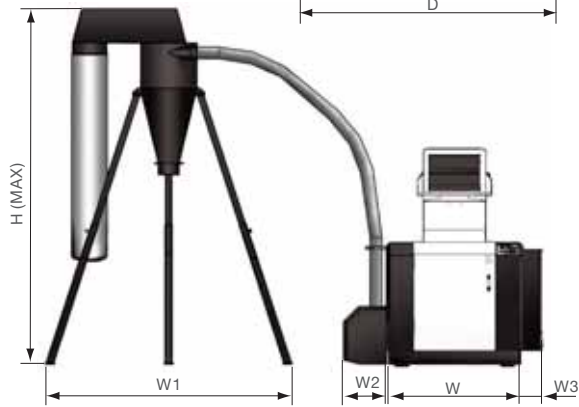
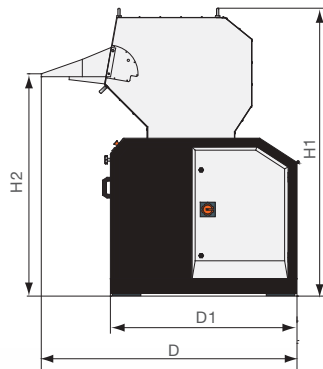

CG-36

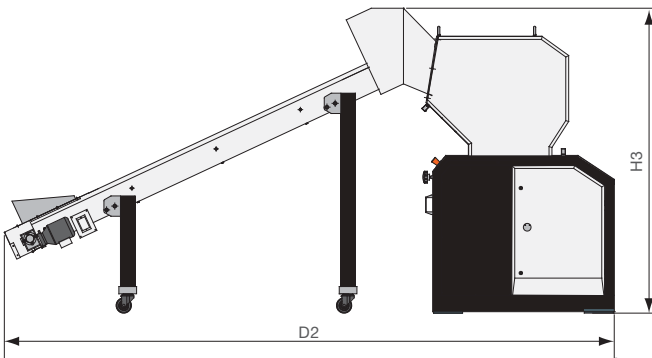

CG-36 with Belt Conveyor

CG-23/30 Specifications

Model	CG-2324	CG-2336	CG-2348	CG-3048	CG-3036
Motor Power (kW, 50/60 Hz)	5.5 / 6.3	7.5 / 8.6	11 / 12.6	11 / 12.6	15 / 17.3
Conveying Blower (kW, 50/60 Hz)	0.55 / 0.66	0.55 / 0.66	0.55 / 0.66	0.55 / 0.66	0.55 / 0.66
Rotor Speed (RPM 50/60 Hz)	415 / 500	415 / 500	415 / 500	415 / 500	415 / 500
Blade Type	Staggered	Staggered	Staggered	Paddle	Staggered
Blade Material	SKD11	SKD11	SKD11	SKD11	SKD11
Number of Fixed Blades	2	2	2	2	2
Number of Rotating Blades	3 x 2	3 x 3	3 x 4	3	3
Cutting Chamber (mm)	230 x 240	230 x 360	230 x 480	300 x 480	300 x 600
Max. Output (kg/hr)	90	120	150	185	220
Noise Level dB(A)	90 ~ 95	90 ~ 95	90 ~ 95	90 ~ 95	90 ~ 95
Regrind Conveyor	✓	✓	✓	✓	✓
Cooling Water Device	✓	✓	✓	✓	✓
Dia. of Screen Hole (φ8 mm)	✓	✓	✓	✓	✓
Dia. of Screen Hole (φ4, φ6, φ10, φ12 mm)	○	○	○	○	○
Presetting Knife Jig	—	—	—	✓	✓
Full Receiver Alarm Device	○	○	○	○	○
Feed Hopper with Magnet	○	○	○	○	○
Dust Separator (DS-23)	○	○	○	○	○
Feed Hopper with Magnet	○	○	○	○	○
Dimensions					
H (mm)	2210	2210	2210	2210	2210
H1 (mm)	265	265	265	360	360
H2 (mm)	1175	1175	1175	1210	1210
W (mm)	1340	1460	1580	1580	1700
W1 (mm)	780	900	1020	1020	1140
W2 (mm)	190	190	190	190	190
D (mm)	1245	1245	1245	1390	1390
D1 (mm)	915	915	915	1010	1010
D2 (mm)	520	520	520	570	570
Weight (kg)	470	520	600	700	780

- Note:**
- ✓ = standard, ○ = optional
 - Stainless steel feed hopper cover plate and storage tank available.
 - When granulating plastics reinforced with fibers (e.g. CPVC), select granulators with a special quenching process in the cutting chamber and blades.
 - SKD11 (1.2379/D2 steel): high carbon, high chromium alloy steel with high wear and corrosion resistance.
 - Optional high rotating blade speed (only for CG-23 series).
 - Max. capacity of machine is subject to diameter of screen size and composition of material.
 - Noise levels vary with different materials and motor types.
 - To avoid plastic from sticking to blades, materials should be crushed at normal temperature.
 - Power supply: 3φ, 230/400/460/575V, 50/60Hz.

We reserve the right to change specifications without prior notice.



COMET

PLASTIC EQUIPMENT, LLC
 6555 Garden Rd. Units 14/15
 Riviera Beach FL 33404
800-328-5088
 Fax: (561) 841-0400