

SD-15/25 and SD-50/65 Small Dryer Series

**100% Stainless Steel Construction
means “Corrosion-Free” Material Drying!**

Comet’s simple, yet solidly constructed SD-Small Dryer Series offers you reliability, durability, and a full TWO YEAR WARRANTY.

The SD-Small Dryer Series incorporates a twin tower design and a completely automatic regeneration cycle for continuous operation. While one desiccant bed is processing, the other is regenerating. After a preset time, the dryer transfer valve shifts and the moist air stream from the hopper is directed through the regenerated desiccant bed where it is dried.

The -40° F dew point air is heated to a temperature adjustable to 300° F or higher. This temperature is precisely maintained by a standard PID solid-state temperature control providing dependable drying without cartridge changing, thus reducing costs. The dryer can be machine-mounted or mounted on an A-frame cart. This space saving construction combined with cost efficiency easily make Comet’s SD-Small Dryer Series the best value on the market today!

The SD-Small Dryer Series comes completely wired and assembled. The only installation required is to prepare a protected electrical connection. It is constructed of stainless steel so all metal which comes in contact with the plastic material will be free from corrosion or contamination. The SD-Small Dryer Series is equipped standard with the latest design in canopy-type diffusers to reduce cleanup time, a clean-out door, and a large sight-glass window for convenience. An *insulated*, stainless steel dryer hopper is also available.

**Compact, twin
tower design for
efficient drying of
plastics resins.**



*SD-15 with 60 lb. insulated drying hopper
on portable stand.*

SD-15/25 Insulated Dryer

with 60 lb. hopper

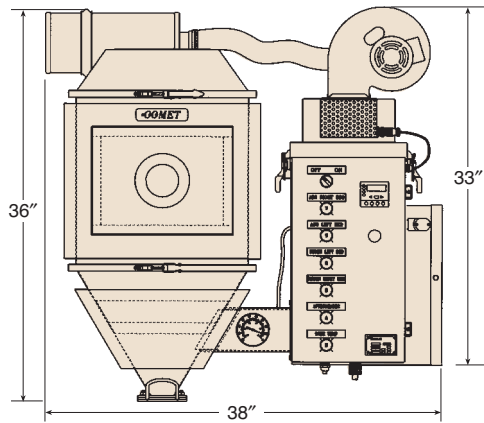

Base Plate

60 lb. & 100 lb. hopper

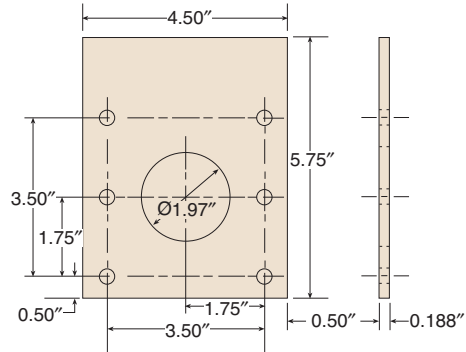

SD-50 Dryer

with 200 lb. hopper & standard control

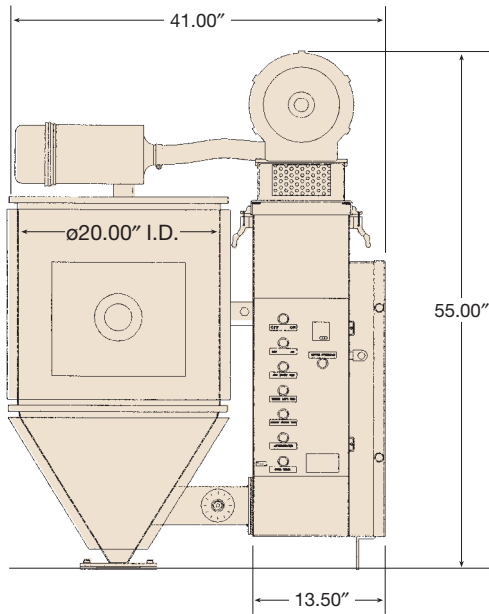

SD-65 Dryer

with 260 lb. hopper & Allen-Bradley control

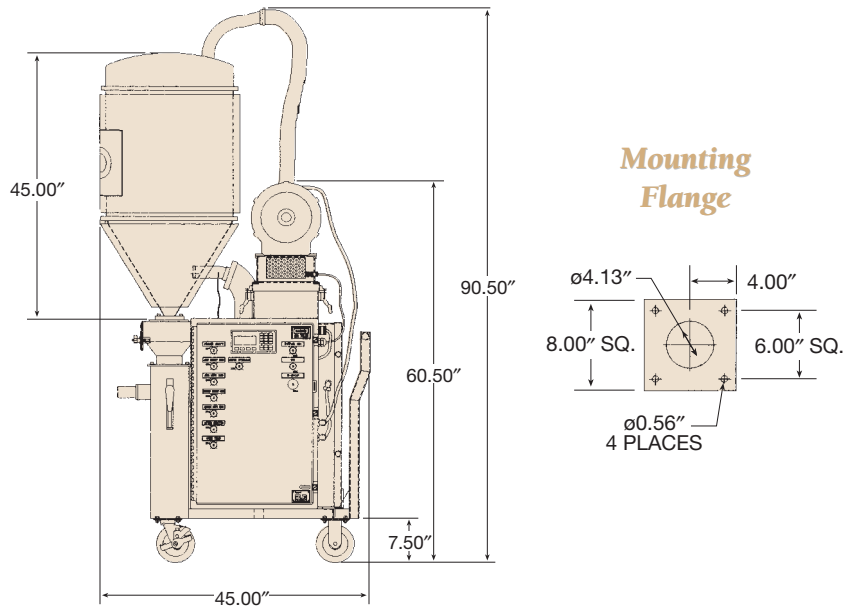

We reserve the right to change dimensions, technical data, and specifications without prior notification.

Comet Automation Systems offers a complete package from one source.

**Storage Silos → Inside Bins → Central Vacuum Conveying → Portable & Central Dryers → Hopper Loaders →
Proportioning Valves → Color Feeders → Central Blending → On-The-Machine Color Blenders →
Weigh/Gravimetric Blenders → Granulators → Mold Monitors
Consultation — Design Engineering — Production — Installation — Service**

Out of Production Product Support Provided by:

COMET
PLASTIC EQUIPMENT, LLC

6555 Garden Rd. Unit 16
Riviera Beach FL 33404
561-842-0011
800-328-5088
comet.pe.com

Scan this QR code
with your mobile
device to see our
complete line of
auxiliary products.

