

## *Series 500 & Series 150*

*Corrosion-free resin blenders for precision metering and mixing of pellets, granulate, free-flowing powders, non-free-flowing powders, and regrinds directly on the processing machine.*



*Comet's stainless steel mixer arm and mix hoppers mean quick cleanup and a long reliable service life ... guaranteed.*



# Series 150

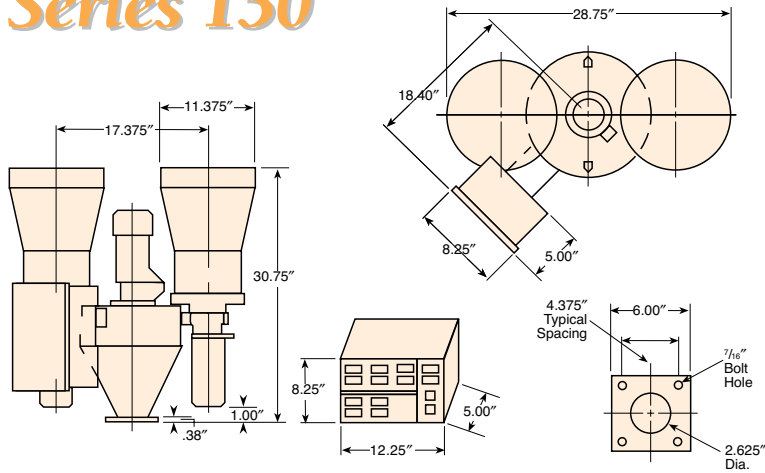

## Series 150 Technical Data

<b>Metering Accuracy</b> (Depending on the material and motor speed)	0.5% - 2% based on 1 minute metering time
<b>Material Throughput</b> (Depending on the material and motor speed)	0 - 250 pounds per hour
<b>Weight</b> (Depending on the number of metering units)	150 - 280 pounds
<b>Power Requirement</b>	115V single phase 60 cycle 0.5 Kw

# Series 500

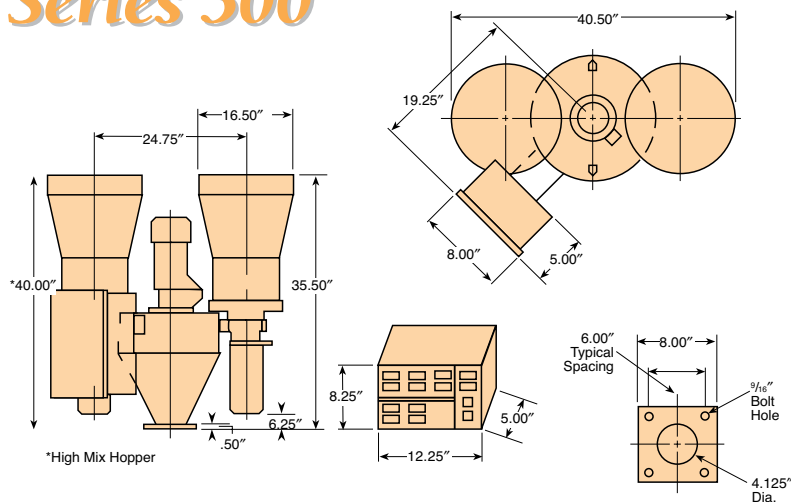

## Series 500 Technical Data

<b>Metering Accuracy</b> (Depending on the material and motor speed)	0.5% - 2% based on 1 minute metering time
<b>Material Throughput</b> (Depending on the material and motor speed)	1,000 pounds per hour (standard mix hopper) 4,000 pounds per hour (extended mix hopper)
<b>Weight</b> (Depending on the number of metering units)	250 - 400 pounds
<b>Power Requirement</b>	110 volt single phase 60 cycle 0.5 - 1 Kw

*We reserve the right to change dimensions, technical data, and specifications without prior notification.*

Comet Automation Systems offers a complete package from one source.

**Storage Silos → Inside Bins → Central Vacuum Conveying → Portable & Central Dryers → Hopper Loaders → Proportioning Valves → Color Feeders → Central Blending → On-The-Machine Color Blenders → Weigh/Gravimetric Blenders → Granulators → Mold Monitors**  
**Consultation — Design Engineering — Production — Installation — Service**

**Out of Production Product Support Provided by:**

**COMET**  
PLASTIC EQUIPMENT, LLC

6555 Garden Rd. Unit 16  
Riviera Beach FL 33404  
561-842-0011  
800-328-5088  
comet.pe.com

Scan this QR code with your mobile device to see our complete line of auxiliary products.

