

CPV Proportioning Valve

Designed to accurately mix and proportion virgin and regrind material.

Comet's corrosion-free, stainless steel CPV Two-Component proportioning valve enables two materials to be conveyed in a preselected percentage through an individual hopper loader or a central vacuum receiver. Material proportion can be digitally set on the electronic control box mounted on the unit. Switching between materials is accomplished using a stainless steel diverter. During a single conveying cycle, it is possible to switch materials (virgin and regrind) as often as desired.

Standard Features

- Guaranteed to never jam while switching between materials.
- Constructed of corrosion-free stainless steel to withstand wear and continuous operation.
- Switch materials (i.e. virgin and regrind) as often as desired during a single conveying cycle.
- Automates feeding of virgin and regrind materials eliminating the possibility of cross-contamination.
- No operator necessary to calculate and set loading timers, ensuring ease of use and the highest mix accuracy possible.
- Requires only one single-phase signal to operate.
- Eliminates virgin and regrind layering common in ratio loaders through in-line mixing.
- Creates a more uniform density of materials making the meld easier to control in the barrel of the processing machine.
- Built-in microprocessor control precisely sets the regrind ratio and cycle time using a keypad with a digital display.
- Connects quickly and easily to any hopper loader or central vacuum system to reduce labor costs.
- Easy to install, easy to use.

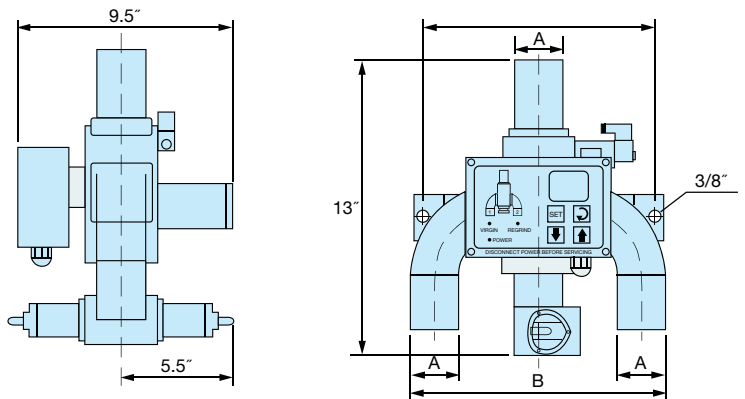

Dimensions	CPV-40	CPV-50	CPV-65
A	1.5"	2"	2.5"
B	10"	10.5"	11"

