

CPV-U Proportioning Valve

Designed to accurately mix and proportion virgin and regrind material.

Comet's CPV-U series proportioning valve utilizes a unique valve body design to smoothly convey virgin and regrind materials to the molding machine in a pre-selected ratio. It can be mounted on an individual hopper loader or onto a pipeline.

After material load time and the proportion is set, the opening and closing start time of the air cylinder controls the feeding proportion of virgin and regrind to the hopper loader.

Standard Features

- Easy installation and operation.
- The valve body's unique design conveys material smoothly.
- The solenoid valve ensures the air cylinder accurately proportions virgin and regrind materials.
- Instantly recycles regrind materials to reduce production cost.
- Select one to four function levels to mix material evenly.
- No need to order a control box when operating with an CAL-U series hopper loader (control box is separate when performing other operations).



CPV-38U-C



CPV-U Back

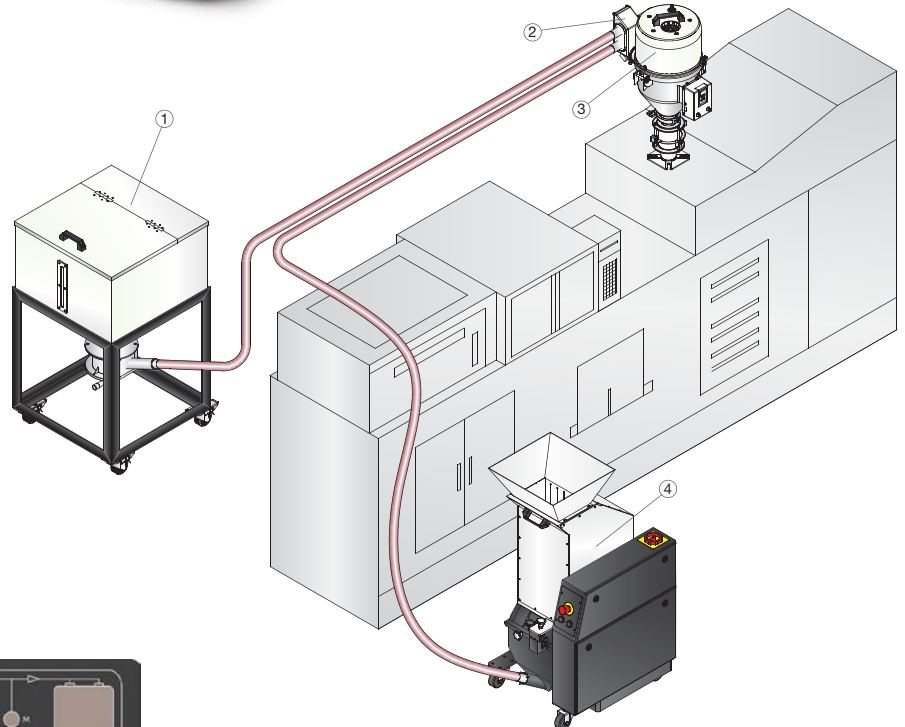

1. Material storage tank
2. Proportioning valve
3. Standard self-contained hopper loader
4. Low-speed granulator



Control

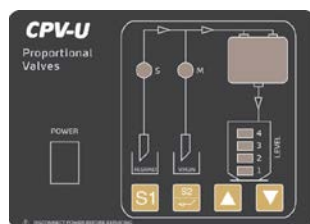

Control Panel

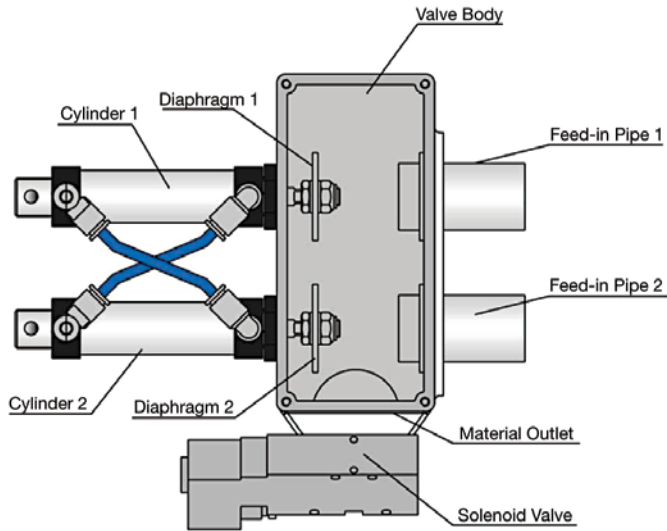

Outline Drawings

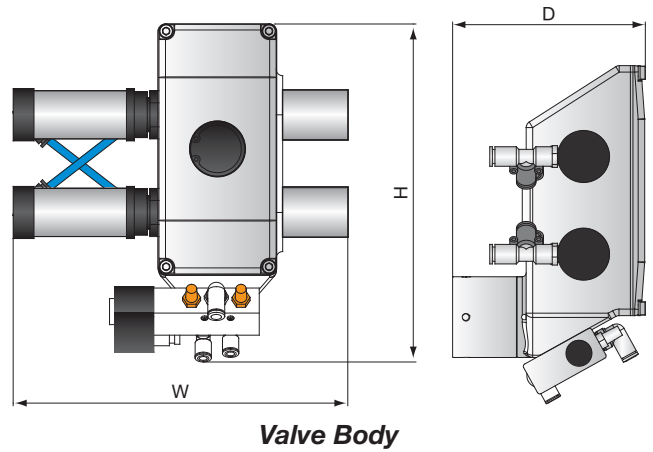

Working Principle

To achieve the proportional mix, set the material load time and proportion of the secondary material. The air cylinder tank will control the feeding proportion of the virgin and secondary material in the hopper by opening, closing and start time of the conical diaphragm 1 and 2.

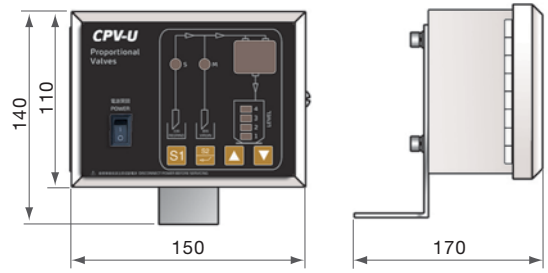

Control Panel

Specifications

| Model | Drive | Compressed Air Pressure | Maximum Material Flow | | Pipe Size | Dimension H x W x D | | Weight | |
|-------------|----------|-------------------------|-----------------------|-----------|-----------|---------------------|-----------------|--------|-----|
| | | | lb/hr | kg/hr | | inch | mm | lb | kg |
| CPV-38U-(C) | Cylinder | 65-80 PSI | 772 lb/hr | 350 kg/hr | 1.5 | 10.6 x 10 x 6 | 270 x 260 x 150 | 7.71 | 3.5 |
| CPV-50U-(C) | Cylinder | 65-80 PSI | 1200 lb/hr | 550 kg/hr | 2 | 10.6 x 10 x 6 | 270 x 260 x 150 | 8.38 | 3.8 |

Notes: 1. C = control cabinet (no need of control box when working with SAL-U loaders)

2. Maximum material flow based on pellet material of 1.43 lbs. (0.65 kg/L) in bulk density and 1/8" - 3/16" (3-5mm) in diameter.

3) Power supply: 1Ø, 115/230VAC, 50/60Hz.

We reserve the right to change specifications without prior notice.